

Dimensions

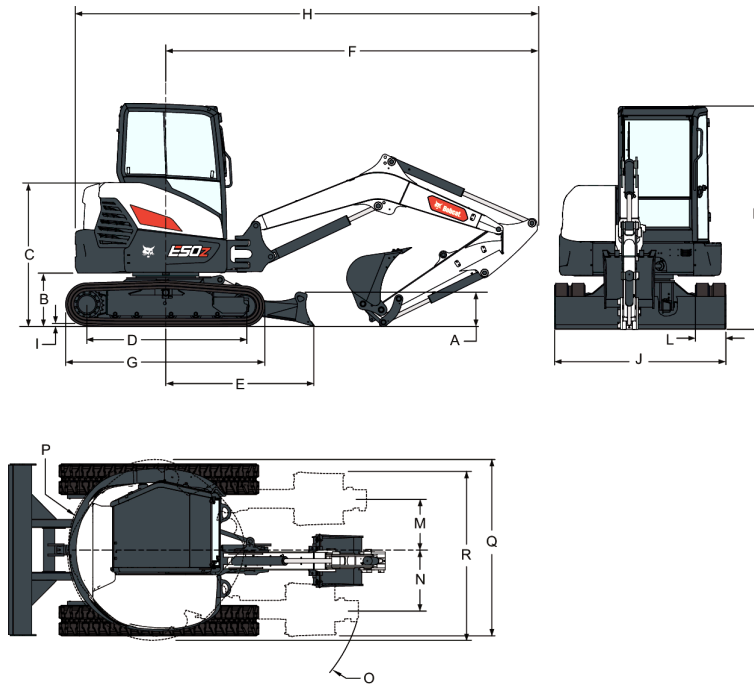

(A) Blade height	373.0 mm
(B) Clearance, upper structure to ground line	608.0 mm
(C) Ground line to top of engine cover	1640.0 mm
(D) Length of track on ground	1803.0 mm
(E) Machine centre line to blade	1692.0 mm
(F) Minimum radius in travel position	4250.0 mm
(G) Overall length of track assembly	2276.0 mm
(H) Overall length in travel position	5395.0 mm
(I) Track lug height	25.0 mm
(J) Blade width	1959.0 mm
(K) Height	2546.0 mm
(L) Track width	350.0 mm
(M) Machine centre line to working equipment centre line, left-hand rotation	527.0 mm
(N) Machine centre line to working equipment centre line, right-hand rotation	872.0 mm
(O) Minimum turning radius	2075.0 mm
(P) Swing clearance, rear	1035.0 mm
(Q) Working width at maximum right-hand rotation	2016.0 mm
(R) Working width at maximum left-hand rotation	2006.0 mm

Working Range

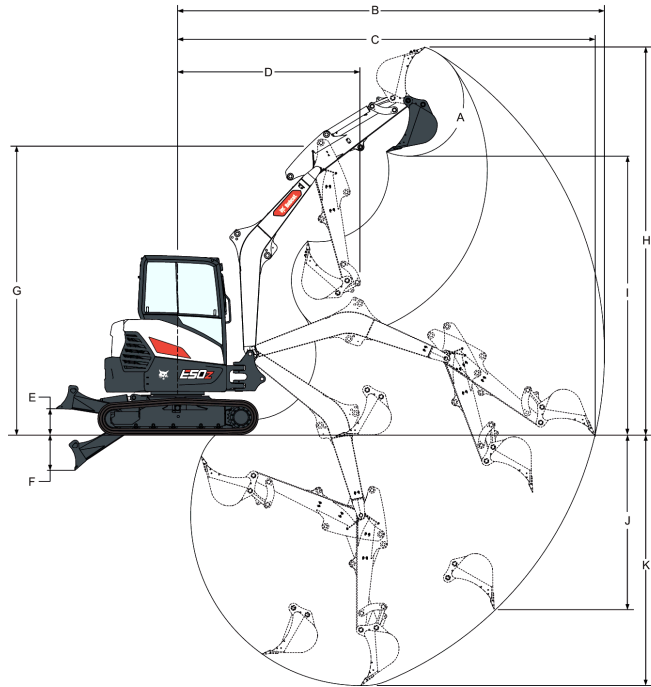

(A) Bucket pivot angle	186.0°
(B) Maximum reach of working equipment	6056.0 mm
(C) Maximum reach at ground level	5922.0 mm
(D) Maximum working equipment radius with boom at maximum height and dipperstick fully retracted	2593.0 mm
(E) Maximum blade height	370.0 mm
(F) Maximum blade depth	502.0 mm
(G) Maximum height of working equipment with dipperstick retracted, long dipperstick	4095.0 mm
(H) Maximum bucket tooth height	5499.0 mm
(I) Maximum dump height	4015.0 mm
(J) Maximum depth of vertical wall which can be excavated	2462.0 mm
(K) Maximum digging depth	3553.0 mm